

D
C
B
A

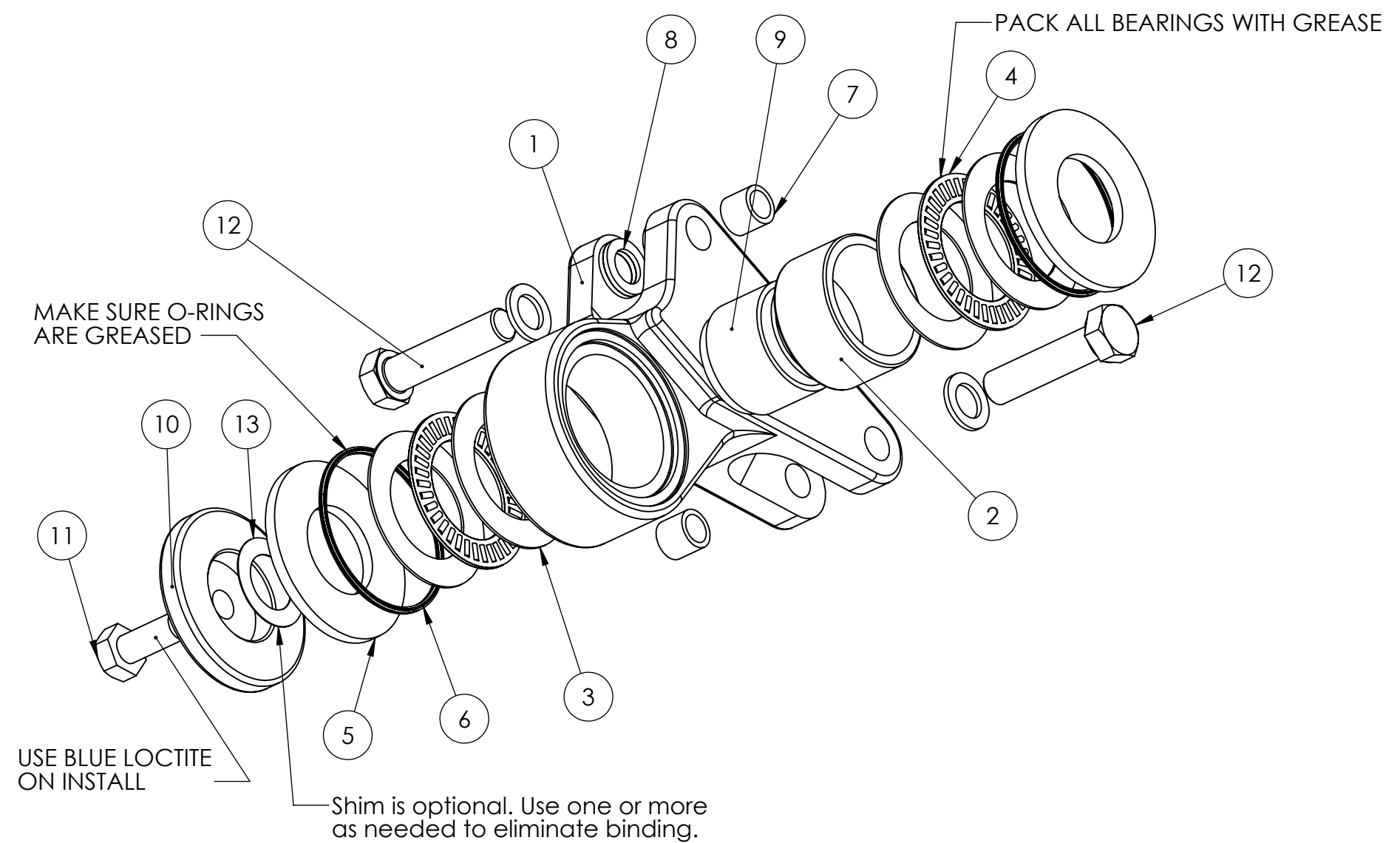

ITEM NO.	PART NUMBER	DESCRIPTION	QTY.
1	9050845	A3 Bellcrank Left	1
2	9050346	Steel Needle Roller Bearing Open 1.25" ID, 1.5"OD, 0.75"W	1
3	9050348	0.032" washer for thrust bearing 1.125" ID	4
4	9050347	Bearing, Thrust, Needle Roller, 1-1/8"x1-3/4"x5/64	2
5	9070316	Washer, 1" ID, 2" OD, .134" thick, steel, zinc	2
6	9070321	O-ring, 1-7/8"ID, 1/16"thck, quad, AS568A-031	2
7	9070037	Helicoil, 3/8-24 x 0.375, Lock	2
8	9070032	Washer, 3/8", 0.63" OD, 0.05" THCK	6
9	9050373	A3 Bellcrank Sleeve	1
10	9050883	A3 Bellcrank Hat	1
11	9070421	Bolt, Hex, Zinc, M8-1.25 x 20	1
12	9070045	Bolt 3/8-24 x 1.5" Drilled Head	2
13	9070426	Shim, 5/8" ID, 1" OD, .010" Thick	1



PROPRIETARY AND CONFIDENTIAL THE INFORMATION CONTAINED IN THIS DRAWING IS THE SOLE PROPERTY OF PALATOV MOTORSPORT LLC. ANY REPRODUCTION IN PART OR AS A WHOLE WITHOUT THE WRITTEN PERMISSION OF PALATOV MOTORSPORT LLC IS PROHIBITED.	UNLESS OTHERWISE SPECIFIED:	NAME	DATE	Palatov Motorsport LLC TITLE: A3 Bellcrank Left Assy	
	DIMENSIONS ARE IN INCHES	DRAWN	TL		11/20/2015
	TOLERANCES: FRACTIONAL ± 1/16 ANGULAR: ± 1 DEG TWO PLACE DECIMAL ± .01 THREE PLACE DECIMAL ± .005	CHECKED			
	INTERPRET GEOMETRIC TOLERANCING PER:	ENG APPR.			
CAD FILE: C:\projects\PM Parts\9050846.SL DPRT	MATERIAL	Q.A.			
	FINISH	COMMENTS:			
	DO NOT SCALE DRAWING			SIZE DWG. NO. REV B 9050846 D	
		SCALE: 1:4	WEIGHT:	SHEET 1 OF 2	

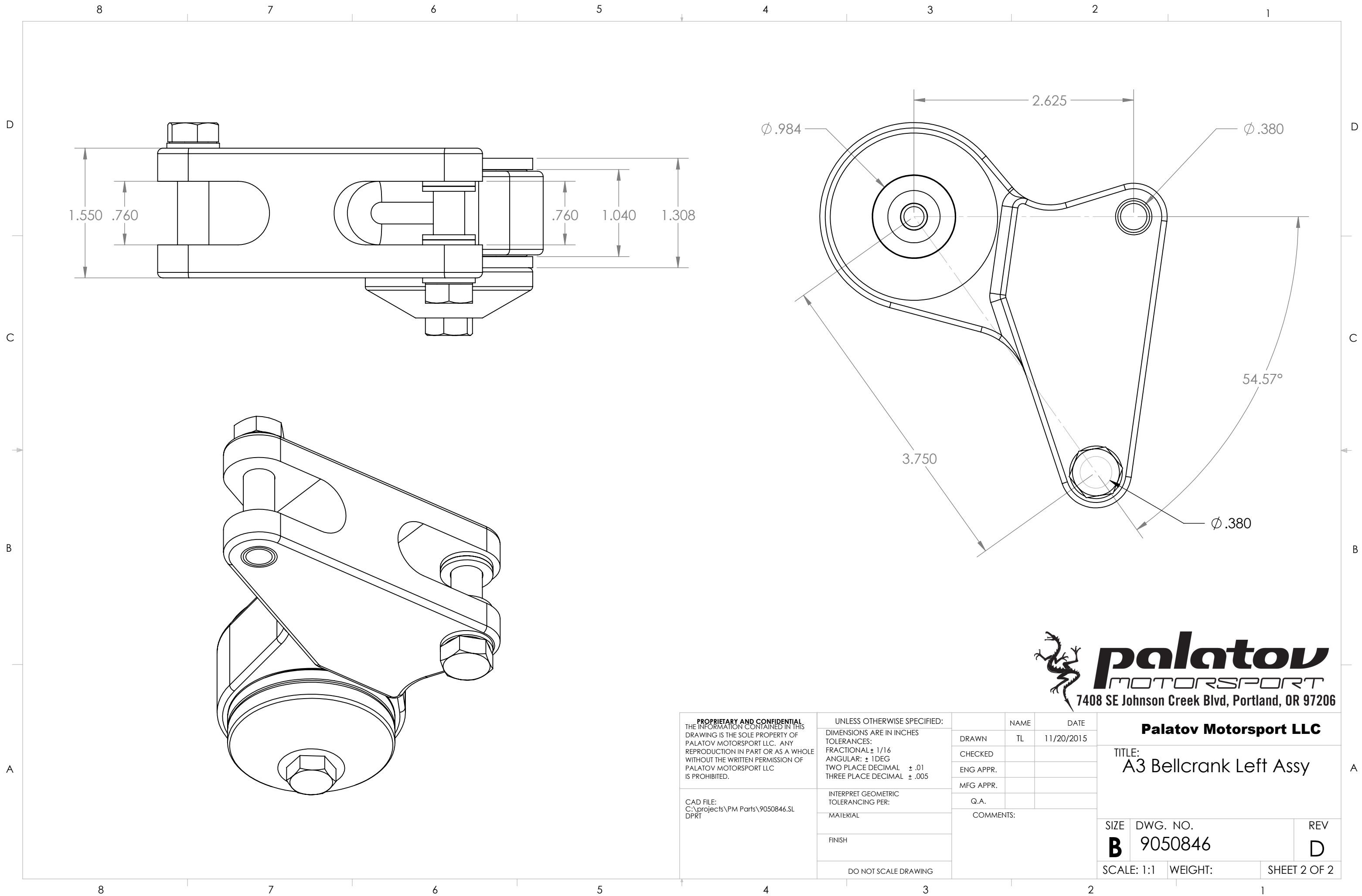

<p>PROPRIETARY AND CONFIDENTIAL THE INFORMATION CONTAINED IN THIS DRAWING IS THE SOLE PROPERTY OF PALATOV MOTORSPORT LLC. ANY REPRODUCTION IN PART OR AS A WHOLE WITHOUT THE WRITTEN PERMISSION OF PALATOV MOTORSPORT LLC IS PROHIBITED.</p> <p>CAD FILE: C:\projects\PM Parts\9050846.SL DPRT</p>	UNLESS OTHERWISE SPECIFIED:			NAME		DATE	<p>Palatov Motorsport LLC</p>	
	DIMENSIONS ARE IN INCHES TOLERANCES: FRACTIONAL ± 1/16 ANGULAR: ± 1DEG TWO PLACE DECIMAL ± .01 THREE PLACE DECIMAL ± .005			DRAWN	TL	11/20/2015		
	INTERPRET GEOMETRIC TOLERANCING PER:			CHECKED				
	MATERIAL			ENG APPR.				
	FINISH			MFG APPR.				
DO NOT SCALE DRAWING			Q.A.			SIZE DWG. NO. REV B 9050846 D		
			COMMENTS:			SCALE: 1:1 WEIGHT: SHEET 2 OF 2		